

Sponge Roller Cleaner SRC-3000

Operation Manual



Thank you for purchasing the SRC-3000.
Read these instructions thoroughly for proper use of this device.
Make sure to read "Safety Notes" before you use the device.
This information protects you from possible dangers during use.

Apollo Seiko Ltd.

Safety Notes

This manual includes the important information to use this device safely. This also includes useful information to prevent avoiding injury or damaging property.

Please read this manual carefully prior to connecting or operating the SRC-3000.

Keep this manual nearby the device all the time.

Supply only specified voltage

Do not connect to a power supply greater than the specified voltage. If not, electrical shock and /or damage to the device may occur.

Make sure that the electrical outlet is properly grounded. If the outlet is not properly grounded, electrical shock and/or damage to the device may occur.

Working ambient temperature and relative humidity

This device has been designed to use between 0~40 degree、10%~90%. Do not use this device under the condition exceeding here-in.

Handle with care

This device is designed to clean the iron tip.

Please be careful your fingers do not get caught in roller sponges.

Please make sure to turn off the power, when you replace sponges.

Please note water does not overflow from the water reservoir. It may cause electric shock or leak.

Please handle the device with care. If you drop or make a big impact/ vibration, it may cause malfunction.

If you note malfunction on unit

If the device become a malfunction, turn off the power immediately and contact a dealer you purchased the device from.

Immunity from responsibility

We do take NO responsibility on a damage caused by misuse, mistake, accident, uses in abnormal condition or natural disaster such as an earthquake, a fire etc.

We do take NO responsibility on contingency loss (Business loss、Business stop) caused by device stop.

We do take NO responsibility on a loss caused by the operation not mentioning on this manual.

We do take NO responsibility on a loss caused by a wrong connection with other equipment.

If for any reason the internal circuitry is tampered with altered or repaired without written consent of Apollo Seiko, the warranty is null and void. The customer is allowed to make necessary tooling adjustment, replace solder iron tips and make any necessary adjustments to the temperature controller.

Index

Safety Notes	2
1. Description	4
2. Maintenance	5
3. Consumables	6
4. Specification	6
5. Dimension	6

1. Description

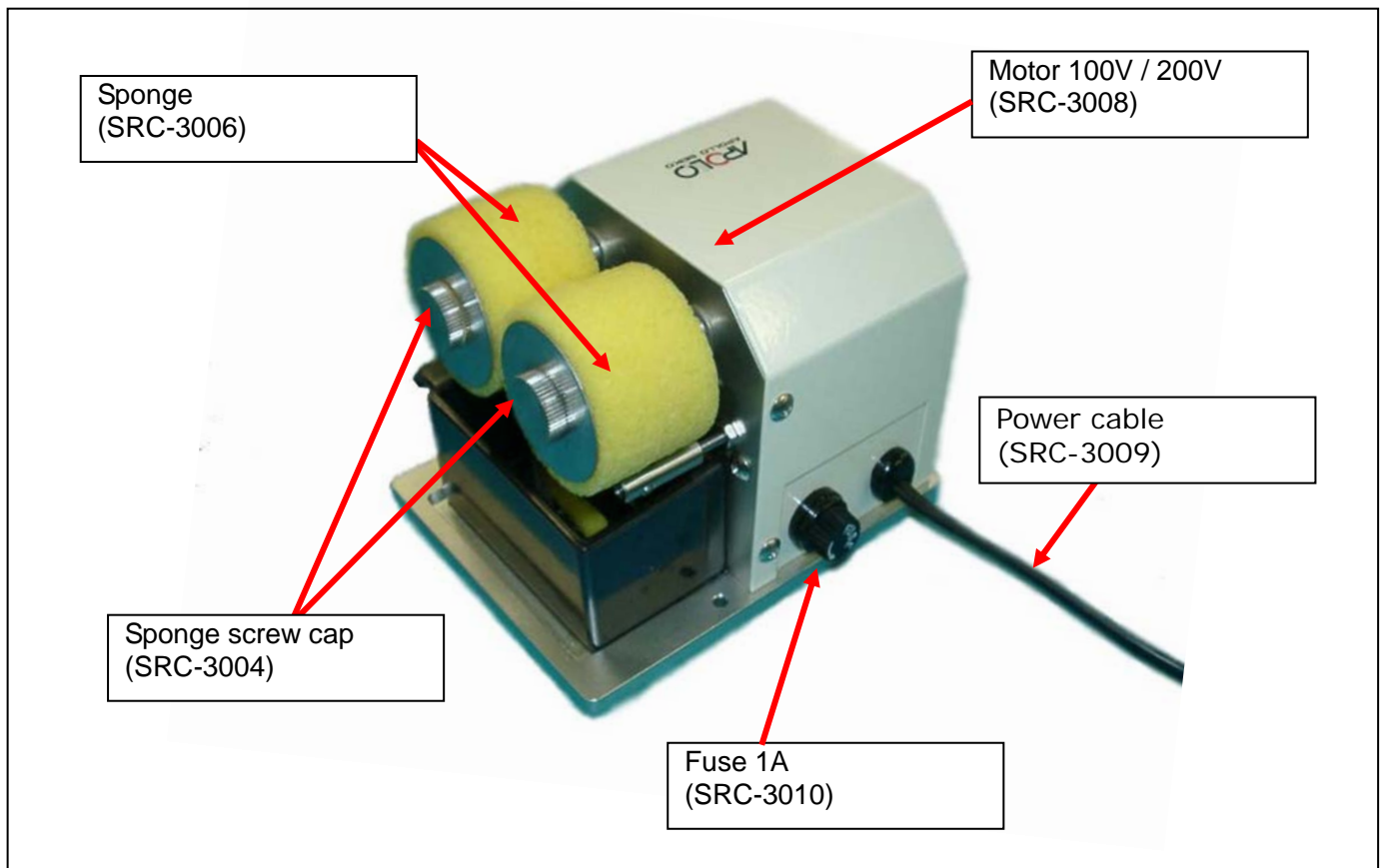
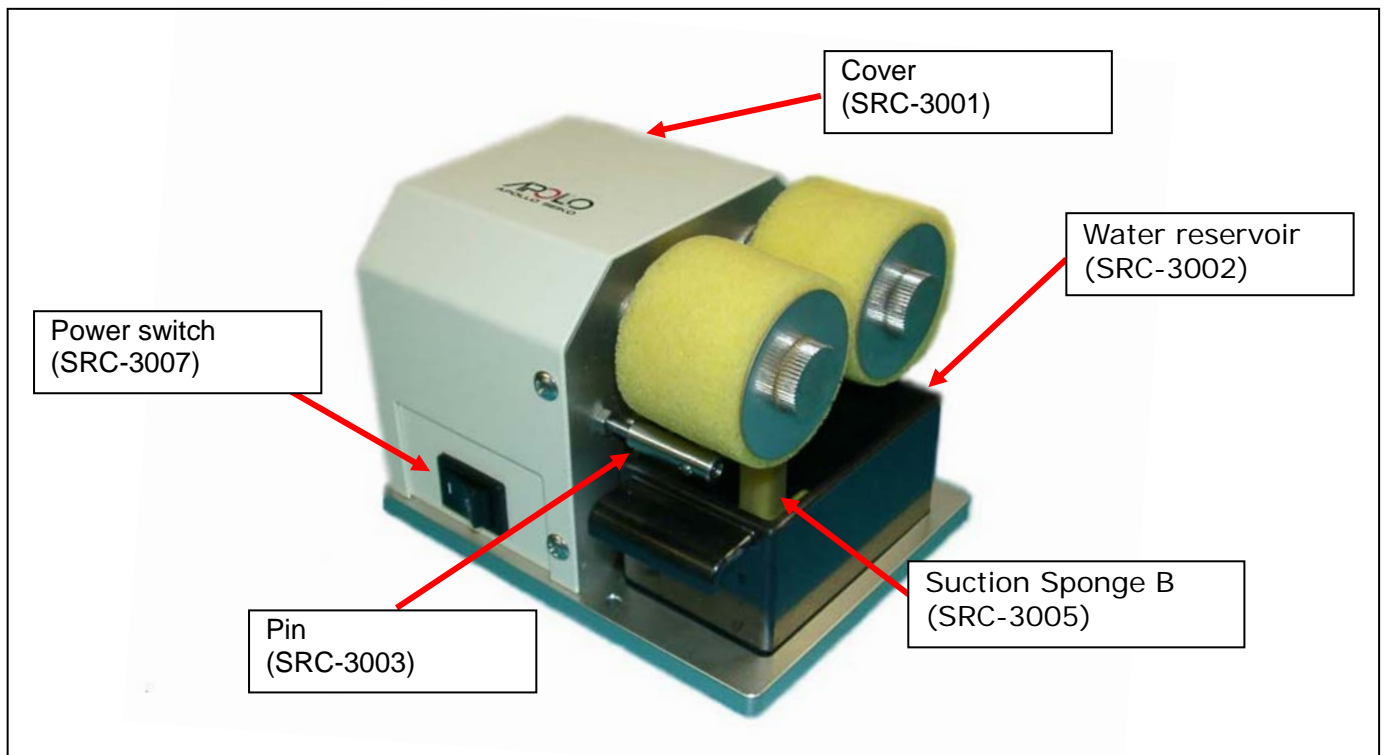

2. Maintenance



Please power OFF, when you work below.

2-1. Replacement of Sponge (SRC-3006) *Before removing,

- Remove the used sponges. *Please moisten the sponges before removing.



Loosen the two nuts.

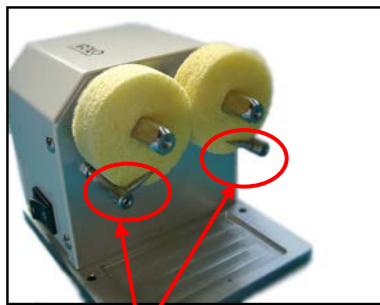

After removing the two front sponges, take the Pin off.

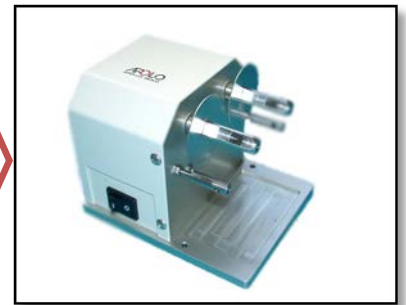

Remove the two back sponges.

- Put the new sponges. *Please use the moistened sponges.

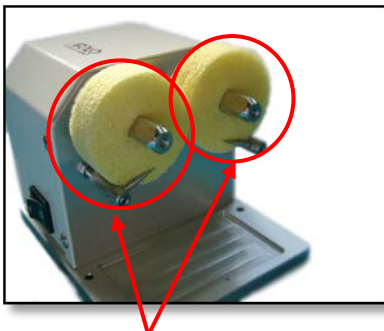

Put new back sponges and pins.

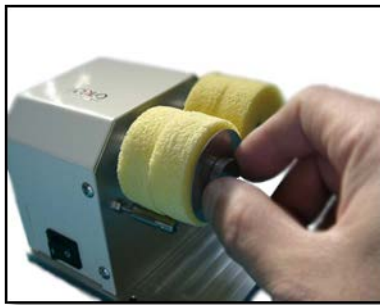

Put new front sponges and tighten the two nuts.

2-2. Replacement of Suction sponge B (SRC-3005)



Moisten the used suction sponge and remove it.



Insert a new moistened sponge and pick out the tip of sponge with a pinch.



3. Consumables

Name	Type
Pin	SRC-3003
Nut	SRC-3004
Suction sponge B	SRC-3005
Sponge	SRC-3006

4. Specification

Dimension	115mm(W) X 90mm(D) X 88mm(H)
Power supply (100V / 220V)	AC-100V / AC220V
Number of Sponge Rotation	Approx. 30rpm
Working Liquid	Tap-water

5. Dimension

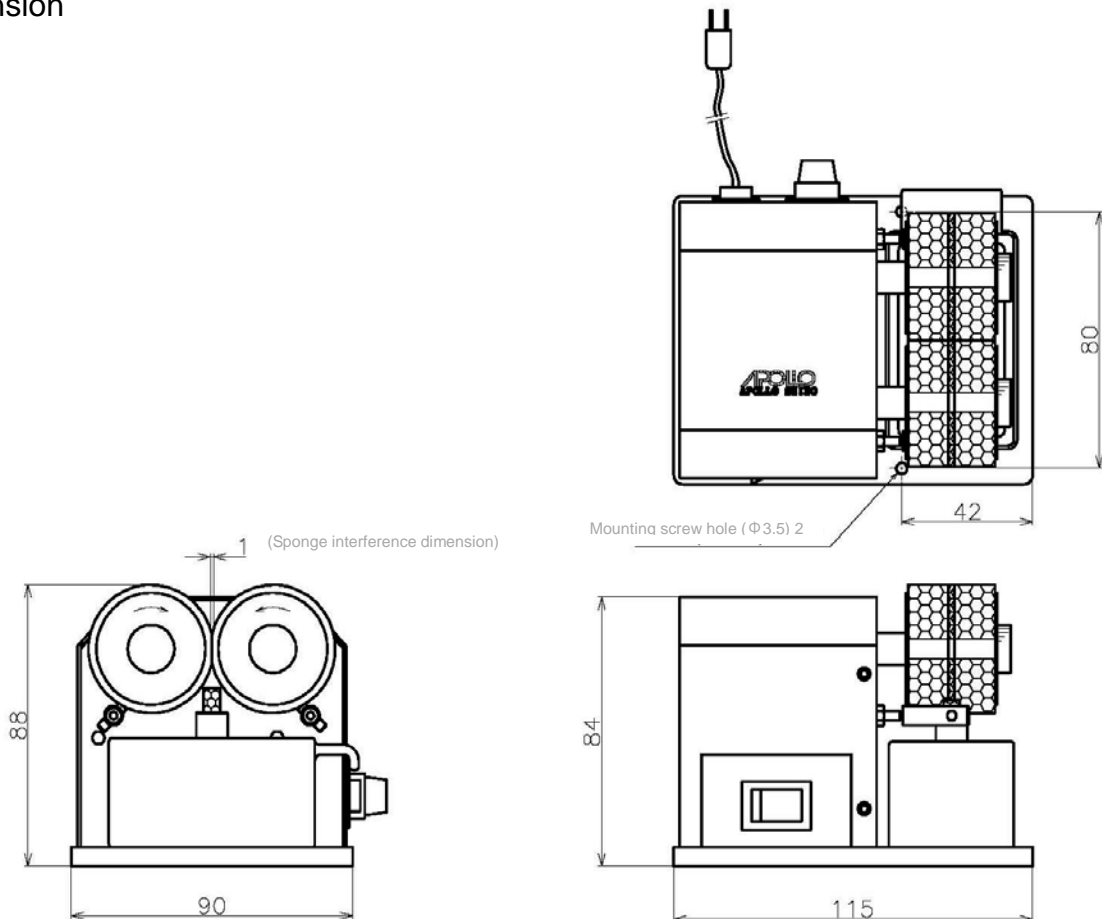

Apollo Seiko Ltd.

2271-7 Jinba, Gotenba-shi,
Shizuoka, Japan

TEL: +81-(0)550-88-2828

FAX: +81-(0)550-88-2830

E-mail: sales@apolloseiko.co.jp

URL: <http://www.apolloseiko.co.jp>